

### SURVEY NARRATIVE

THIS SURVEY WAS PERFORMED AT THE REQUEST OF ANDY LINDSEY. THE PURPOSE OF THIS SURVEY WAS TO PERFORM A LOT LINE ADJUSTMENT BETWEEN LINDSEY'S PROPERTY (WARRANTY DEED - DOCUMENT #20074966), AND LINDSEY'S PROPERTY (WARRANTY DEED - DOCUMENT #20076712). THE MONUMENTS FROM MINOR PARTITION PLAT 20070031T AND OTHER SURVEYS AS SHOWN WERE USED TO CONTROL THE EXTERIOR BOUNDARY OF BOTH PARCELS AS SHOWN. THE FOUND MONUMENTS ALL FIT WELL WITH RECORD CALLS, AS SHOWN HEREON. THE SET MONUMENTS WERE SET PER THE DIRECTION OF ANDY LINDSEY. NEW LEGAL DESCRIPTIONS OF THE ADJUSTED PARCELS HAVE BEEN PREPARED AND SUBMITTED TO THE UNION COUNTY PLANNING DEPARTMENT.

### BASIS OF BEARINGS

N89°41'13"E BETWEEN FOUND MONUMENTS ALONG THE SOUTH LINE OF PARCEL 2 OF PARTITION PLAT 20070031T AS SHOWN HEREON.

### LEGEND

- INDICATES SET 5/8 INCH IRON ROD, 30 INCHES LONG WITH 1 1/2" DIA. ALUMINUM CAP STAMPED "APA WA41295 OR2B49"
- ⊕ INDICATES FOUND MONUMENT AS DESCRIBED HEREON
- ⊗ INDICATES MONUMENT POINT NUMBER. SEE TABLE BELOW
- INDICATES RECORD DIMENSION PER UNION COUNTY PARTITION PLAT 20070031T
- - - INDICATES MONUMENT SEARCHED FOR AND NOT FOUND
- - - - - INDICATES EASEMENT LINE
- |--- INDICATES RIGHT OF WAY CENTERLINE
- x - x - INDICATES EXISTING FENCE LINE
- - - - - INDICATES OLD LOT LINE PER UNION COUNTY PARTITION PLAT 20070031T
- ▨ INDICATES AREA OF ADJUSTMENT-ACCURIES TO PARCEL 1

REGISTERED PROFESSIONAL LAND SURVEYOR  
 OREGON  
 JANUARY 20, 1998  
 MICHAEL B. POSADA  
 02819LS  
 EXPIRES: 12-31-08  
 DATED: 02-20-08

### REFERENCES

- UNION COUNTY MINOR PARTITION PLATS- 20070031T, 1992-015, 20060014T, 2002-010.
- UNION COUNTY SURVEYS - 023-2000, 2007-007.
- UNION COUNTY DEEDS - INSTRUMENT# 20074966 AND 20076712.
- PRELIMINARY TITLE REPORT-ABSTRACT AND TITLE COMPANY, TITLE NUMBER 45835, DATED OCTOBER 8, 2007.

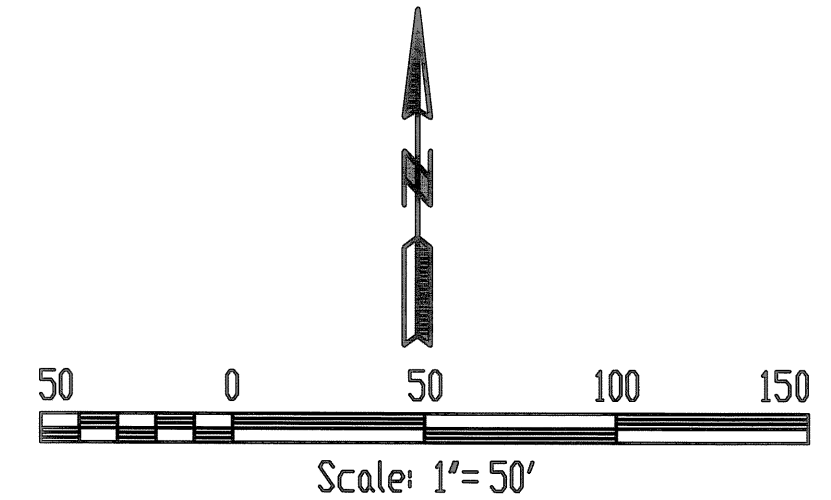

SURVEY NUMBER 001-2008

DATE OF SURVEY: DECEMBER 20, 2007

### MONUMENT RECOVERY TABLE

POINT NO.	DATE	DESCRIPTION AND REFERENCE DOCUMENTS
1	20 DEC 07	FD. 5/8" IRON ROD, BURIED 0.2', WITH PLASTIC CAP MKD. "BGA SURVEY MARKER", (SURVEY 023-2000)
2	20 DEC 07	FD. 5/8" IRON ROD, BURIED 0.3', WITH PLASTIC CAP MKD. "BGA SURVEY MARKER", (MINOR PARTION PLAT 1992-015)
3	20 DEC 07	FD. 5/8" IRON ROD, ABOVE GROUND 0.5', WITH PLASTIC CAP MKD. "BGB SURVEY MARKER", (MINOR PARTITION PLAT 20070031T)
4	20 DEC 07	FD. 5/8" IRON ROD, ABOVE GROUND 0.5', WITH PLASTIC CAP MKD. "BGB SURVEY MARKER", (MINOR PARTITION PLAT 20070031T)
5	20 DEC 07	FD. 5/8" IRON ROD, BURIED 0.1', WITH PLASTIC CAP MKD. "BGA SURVEY MARKER", (MINOR PARTITION PLAT 1992-015)
6	20 DEC 07	FD. 5/8" IRON ROD, BURIED 0.1', WITH PLASTIC CAP MKD. "BGA SURVEY MARKER", (MINOR PARTITION PLAT 1992-015)
7	20 DEC 07	FD. 5/8" IRON ROD, FLUSH IN GROUND, WITH PLASTIC CAP MKD. "BGB SURVEY MARKER", (MINOR PARTITION PLAT 20060014T)
8	20 DEC 07	FD. 5/8" IRON ROD, FLUSH IN GROUND, WITH PLASTIC CAP MKD. "BGB SURVEY MARKER", (MINOR PARTITION PLAT 2002-010)
9	20 DEC 07	FD. 5/8" IRON ROD, FLUSH IN GROUND, WITH PLASTIC CAP MKD. "BGB SURVEY MARKER", (MINOR PARTITION PLAT 20070031T)
10	20 DEC 07	FD. 5/8" IRON ROD, FLUSH IN GROUND, WITH PLASTIC CAP MKD. "BGB SURVEY MARKER", (SURVEY 2007-007)
11	20 DEC 07	FD. 5/8" IRON ROD, FLUSH IN GROUND, WITH PLASTIC CAP MKD. "BGB SURVEY MARKER", (SURVEY 2007-007)

UNION COUNTY SURVEYOR  
 Date Received 2/20/08  
 Date Filed 2/20/08  
 By R. Robinson, Dana  
 File No. 001-2008

MAP OF SURVEY  
 LOT LINE ADJUSTMENT  
 PARCEL 2 - PARTITION PLAT No. 20070031T  
 UNION COUNTY OREGON  
 SE 1/4 OF THE SW 1/4, SECTION 10, T.35., R.40E. W.M.,

ANDREW S. LINDSEY AND PATRICIA O. LINDSEY  
 P.O. BOX 155  
 COVE, OR. 97024

SCALE: 1" = 50'  
 DATE: FEB., 2008  
 JOB NO. 2731-76(100)

anderson perry & associates, inc.  
 ENGINEERING · SURVEYING · MATERIALS TESTING  
 LA GRANDE, OR. WALLA WALLA, WA

SHEET 1/1

SURVEY NUMBER 001-2008